



HARKEN[®]

**Carbo Racing Foil
Instruction Manual**

Unit 0, 1, 2, 3



WARNING! Strictly follow all instructions to avoid an accident, damage to your vessel, personal injury or death. See www.harken.com for additional safety information.

Pre-Assembly

Size Check

Max	Unit 0	Unit 1	Unit 2	Unit 3
Wire	1/4" (6mm)	5/16" (8mm)	3/8" (10mm)	7/16" (11mm)
Rod	-10 (6.35mm)	-17 (8.38mm)	-25 (10.31mm)	-30 (11.1mm)

Unit 0	Foil Length	Max. Headstay
7000.9 m	29' 6" (9m)	32' 9" (10m)
7000.12 m	39' 4" (12m)	42' 8" (13 m)
7000.15 m	49' 2" (15m)	52' 6" (16m)
Unit 1	Foil Length	Max. Headstay
7001.12 m	39' 4" (12m)	42' 8" (13m)
7001.16 m	52' 6" (16m)	55' 9" (17 m)
7001.20 m	65' 7" (20m)	68' 11" (21m)
Unit 2	Foil Length	Max. Headstay
7002.16 m	52' 6" (16m)	56' 6" (17.2m)
7002.20 m	65' 7" (20m)	69' 7" (21.1m)
7002.24 m	78' 9" (24m)	82' 9" (25.2m)
Unit 3	Foil Length	Max. Headstay
7003.24 m	78' 8-1/2" (24 m)	82' 8" (25.2 m)
7003.28 m	91' 10" (28 m)	95' 9" (29.2 m)



Description	Unit 0	Unit 1	Unit 2	Unit 3
Extrusion	H-37931B	H-36315B	H-37820B	H-41360
Trim Cap	H-37932B	H-34427B	H-37833B	H-41337
Feeder	H-37934C	H-34394C	H-37838C	H-41315
Spacer Tube	Upper	H-37935A	H-34433A	H-37879A
	Lower	H-37936A	H-34432A	H-37880A
Prefeeder	7006	7006	7006	7006
PVC Tape	HCP1748	HCP1748	HCP1748	HCP1748
Chafe Guard	7000.30	7001.30	7002.30	—

Fasteners		
Unit 0	HFS1048	6-32x.375 Trusshead Screw
	HFS1049	6-32x.375 Barrel Nut
	HFS699	6-32x.625 Flathead Screw
Unit 1	HFS1048	6-32x.375 Trusshead Screw
	HFS1049	6-32x.375 Barrel Nut
	HFS1047	6-32x.75 Flathead Screw
Unit 2	HFS1094	6-32x.5 Trusshead Screw
	HFS1049	6-32x.375 Barrel Nut
	HFS1093	6-32x.875 Flathead Screw
Unit 3	HFS347	8-32x.5 Trusshead Screw
	HFS1139	8-32x.5 Barrel Nut
	HFS1138	8x32x1 Flathead Screw

Tools



Required

- Phillips Head Screwdriver
- Flat Bladed Screwdriver
- Hacksaw
- Pliers
- Tape Measure
- Drill with 3/16" (5mm) bit or 1/4" (6mm) Unit 3 only

Recommended

- Heat Gun for cool weather



Sail Specifications

- | Unit | Luff Tape |
|------|----------------------------------|
| #0 | #5-5/32" (4mm) |
| #1 | #6-3/16" (5mm) |
| #2 | #6-3/16" (5mm) |
| #3 | #6-3/16" (5 mm) & #7-7/32" (6mm) |

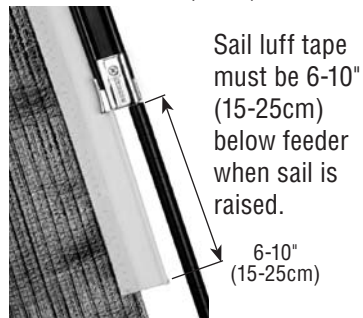

- Recommended height above deck:
- Feeder: 42" (110cm).
- Prefeeder: 30" (76cm).

Pre-Assembly

1. Lay Out Foil

Unroll foil and let it relax for a day or so before installing.

2. Feeder Height



Measure 42" (110 cm) from deck and mark stay.

3. Foil Length

Attach tape measure to halyard.



Measure exposed portion of stay from underside of terminal aloft to mark made in step 2. Deduct 5" (127 mm) for upper spacer tube.

4. Cutting Foil



Mark foil using measurement from step 3. CUT TOP END ONLY. Don't cut bottom of foil with Harken® labels and feeder hole.

4. Continued



Cut upper end of foil with hacksaw.

5. Trim Cap Hole

Place foil so side grooves face up. Slip cap on foil so split end is over groove and large hole faces up.



Tip: Trim cap holes are different diameters. Make sure 3/16" (5 mm) drill bit fits through hole and foil side grooves face up.



Squeeze cap with pliers. Keep drill straight and drill a 3/16" (5 mm) hole part way through foil. Remove cap and finish drilling. Check fit of trim cap, screw and barrel nut. Adjust hole as needed.

Make sure headstay is taut on boat or stretched taut on ground before installation.

Installation

1. Upper Spacer Tube



Splay 5" (127 mm) upper spacer tube with flat bladed screwdriver, slip onto stay and tape.



Important: Tape full length of spacer tube.

2. Foil Start

Identify top of foil. Side groove will be on starboard.

Tip: In cool weather, use a heat gun to warm foil.



Splay foil with screwdriver and pull onto stay. Once foil is started, stop to install trim cap.

Tip: Foil installs easier if excess is held out to starboard side of boat.

3. Trim Cap



Place trim cap on foil so slot is aft, with large hole on starboard. Squeeze together with pliers. Put blue Loctite® in barrel nut. Install two-piece screw and barrel nut with Phillips screwdriver.

4. Foil



Snap foil into place by pulling aft with one hand, while sliding foil up with the other. Use heat gun.

Tip: Use liquid soap to lubricate headstay and foil.

Do not spray McLube to lubricate headstay and foil. See Maintenance on Page 8 for details.

Installation

5. Feeder



Slip feeder into place and firmly push upwards.



Coat screw with blue Loctite® and tighten. If screw does not thread, check alignment.

6. Bottom Tube

Push foil up as far as it will go.



Measure length from feeder to bottom of exposed stay, for lower spacer tube length.



Cut, splay, and snap tube into place.



Tape full length of lower spacer tube.

7. Prefeeder



Measure 12" (300mm) below feeder and lash prefeeder to tube.



Tape prefeeder in place.

Installation

Halyard Lead

Halyard must be parallel to stay. If halyard pulls at an aft angle, it will pull out luff tape and damage foil grooves.

Quieting Bare Foil in Strong Wind

While motoring or moored in high wind, bare foil oscillates, creating an annoying noise. To prevent this, wrap jib halyard around foil four to six times, secure to deck fitting (foreguy bail), and hand tension at winch.

Chafe Guard

Before installing, sail with spinnaker a few times to produce a few wear marks. Chose location to cover marks. Squeeze bead of silicone sealant up length of each inside edge of guard. Press in place. Use supplied PVC tape to hold guard securely for 24-hours before using.

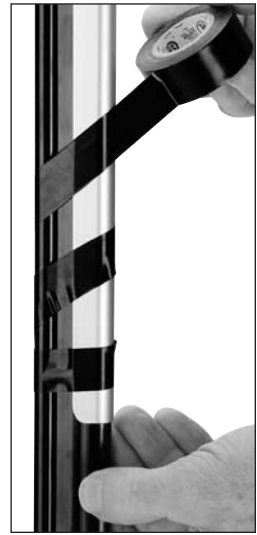
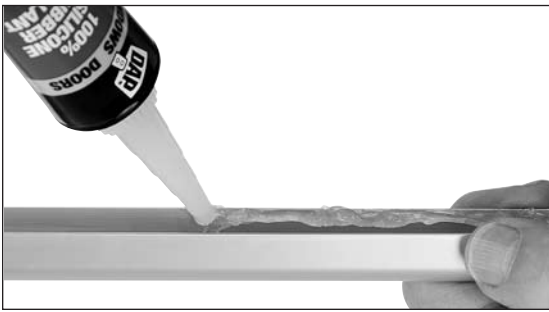

Using Carbo Racing Foil

Raising Sail

Use prefeeder when raising sail. Raise sail completely and tension halyard before sheeting. Sheeting sail too soon can damage luff tape and foil.

Sail Misfeed

To prepare for the rare occasion when a sail misfeeds, some grand prix sailors drill a small exit port (shown at right). If sail jams on hoist, lower until misfeed runs down into gap, then re-hoist.



Troubleshooting—Installation		
Problem	Probable Cause	Solution
Foil is difficult to start onto stay	Foil is stiff from cold	Heat foil to improve flexibility
	Too much friction from stay	Check diameter of stay. See specifications on Page 2.
Foil is curved when unrolled	Foil has taken set	Unroll foil and let it relax in warm conditions
Trim cap does not fit	Trim cap is incorrectly aligned	Place cap on foil with split side on groove side and large hole on starboard
	Hole drilled incorrectly	Examine hole and ream out so it fits
Difficult to snap foil on stay	Stay is too loose	Tension stay, if on ground stretch taut between two solid attachments
	Needs more upward movement	Pull foil in and up. Push down on foil if installing on land.
Feeder does not fit	Feeder is on upside down	Remove feeder and install so side groove is on starboard

Troubleshooting—Use		
Problem	Probable Cause	Solution
Bare foil is noisy in wind	Needs to be stabilized	Wrap jib halyard around foil 4-6 times, secure to deck and hand tension at winch.
Sail luff tape comes out of groove	Luff tape too small	Check to see if luff tape is #6, 3/16" (5 mm) in diameter.
Top of luff tape does not feed into feeder or catches	Luff tape is frayed	Trim loose material with hot knife. Smooth with sandpaper.
Bottom of luff tape pulls out of plastic foil	Luff tape is cut too short	Install longer luff tape so it protrudes 6" (15cm) below feeder.
Top of luff tape pulls out of plastic foil	Halyard angles too far aft	Change location of halyard sheave so halyard is parallel to stay.
Top of sail has pulled out of foil above feeder	Halyard has yanked luff tape out of foil	Remove feeder to re-feed. Drill hole in foil just above feeder to re-feed future pull-outs.
Sail will not raise or lower easily, too much friction	Halyard sheave is jammed	Check sheave bearings and sideload bearings.
	Dirt or other material in foil grooves.	Make a cleaner out of piece of luff tape and grommets.
	Luff tape is too large	Install correct luff tape. System 7000 uses #5, 5/32" (4mm); System 7001, 7002 uses #6, 3/16" (5mm).
	Luff tape is damaged or dirty	Clean sail luff tapes and lubricate with thin film of McLube®. Spray on shore, away from Carbo Racing Foil and boat. Replace or repair as necessary.
Luff tape needs lubrication	Luff tape needs lubrication	Clean sail luff tapes and lubricate with thin film of McLube®. Spray on shore, away from Carbo Racing Foil and boat. Let McLube dry completely before feeding sail into foil. McLube or other toluene- or acetone-based lubricants must not be sprayed near foil. Use McLube on sails but not on Carbo Foil.
	Luff tape damaged after raising sail	Load put on sail before it is raised
Luff tape damaged after raising sail	Load put on sail before it is raised	Raise sail and tension halyard before sheeting

Maintenance

Harken equipment requires minimal maintenance, but some is required to give the best service and to comply with Harken's limited warranty.

It is important to keep equipment clean by frequently flushing with fresh water. In corrosive atmospheres, stainless parts may show discoloration around holes, rivets and screws. This is not serious and may be removed with a fine abrasive.

Sails—Keep sail luff clean and inspect for signs of damage and fraying and repair if necessary.

The Carbo foil material is slippery. If more lubrication is required, spray a thin coat of McLube® **on sail luff tapes away from Carbo Racing Foil and boat deck. Be sure to let sail dry before feeding sail into foil.**



CAUTION! Be sure to read instructions on McLube can before using. Spray McLube on sails in a well-ventilated area, away from the Carbo Racing Foil. Let McLube dry completely before feeding sail into foil. McLube or other toluene- or acetone-based lubricants must not be sprayed on or near foil. Spraying McLube directly on Carbo Racing Foil may damage it.



WARNING! Do not spray foil on boat. McLube will cause slippery decks which may result loss of footing, falling overboard and personal injury or death.

Storing

If storing mast down, foil should be reasonably straight, foil groove down to avoid water and ice buildup.

Before stepping mast, use soap and water to clean Carbo Racing Foil grooves.

Warranty

For additional safety, maintenance and warranty information see www.harken.com or the Harken® catalog.

HARKEN®

1251 East Wisconsin Avenue, Pewaukee, Wisconsin 53072-3755 USA
Telephone: (262) 691-3320 • Fax: (262) 691-3008
Web: www.harken.com • Email: harken@harken.com



Printed in USA 4364/02/01/10