

## ONLINE INSTRUCTIONS

### 32 mm Big Boat CB Traveler Track

R32.1.5M, R32.1.8M, R32.2.1M, R32.2.4M, R32.3M, R32.3.6M, R32.6M,  
 R32HB.1.5M, R32HB.1.8M, R32HB.2.5M, R32HB.3.6M, 3159.8, 3159.12



Strictly follow all instructions to avoid an accident, damage to your vessel, personal injury or death. See [www.harken.com](http://www.harken.com) for additional safety information.

**IMPORTANT: See Inspection and Maintenance at end of manual.**

### Features

Extruded from 6061-T6 aluminum for strength and durability  
 Hardkote anodized with black additive for maximum protection  
 Predrilled holes for end controls and stops on R32 Low-Beam Track  
 All R32 low-beam track has pinstop holes to fit a variety of car types

### R32 Low-Beam CB Track—Fasteners 3/8" (10 mm) FH

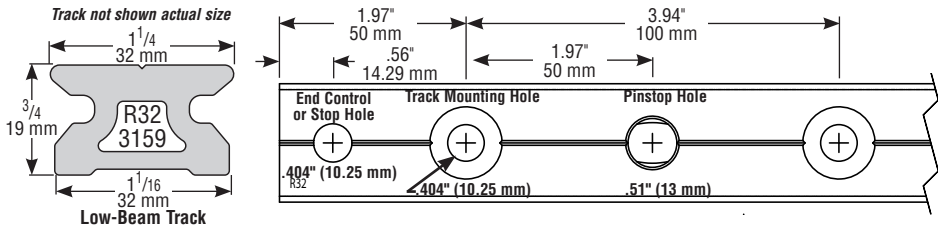

Part No.	Length		Mounting/pinstop hole spacing		Fasteners		Endstop*/trim cap*	Splice link
	ft/in	m	in	mm	in	mm		
R32.1.5m	4'11 1/16"	1.5	3 15/16	100*	3/8 FH	10 FH	E3200/3157	3153
R32.1.8m	5'10 13/16"	1.8	3 15/16	100*	3/8 FH	10 FH	E3200/3157	3153
R32.2.1m	6'10 11/16"	2.1	3 15/16	100*	3/8 FH	10 FH	E3200/3157	3153
R32.2.4m	7'10 1/2"	2.4	3 15/16	100*	3/8 FH	10 FH	E3200/3157	3153
R32.3m	9'10 1/8"	3	3 15/16	100*	3/8 FH	10 FH	E3200/3157	3153
R32.3.6m	11'9 3/4"	3.6	3 15/16	100*	3/8 FH	10 FH	E3200/3157	3153
R32.6m	19'8 1/4"	6	3 15/16	100*	3/8 FH	10 FH	E3200/3157	3153

Not for spanning, see mounting instructions \*Sold in pairs

### R32HB Variable Hole Spacing CB Track/High Beam—Fasteners 5/16" (8 mm) HH

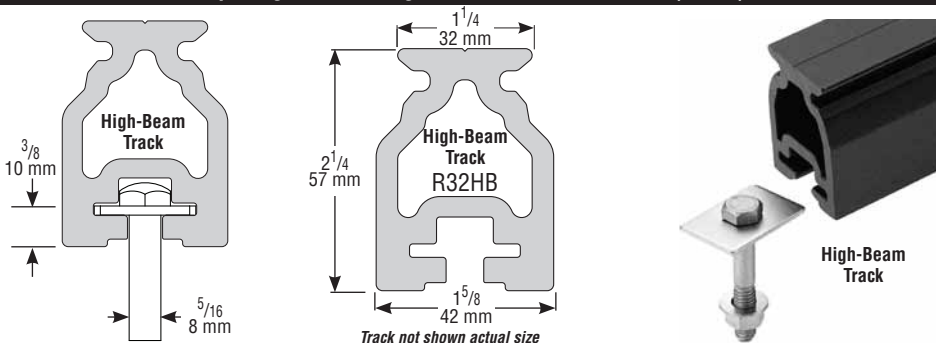

Part No.	Length		Mounting hole spacing	Fasteners		Endstop*/trim cap*	Track riser
	ft/in	m		in	mm		
R32HB.1.5m	4'11 1/16"	1.5	Slide bolt	5/16 HH	8 HH	562/3158	1849
R32HB.1.8m	5'10 7/8"	1.8	Slide bolt	5/16 HH	8 HH	562/3158	1849
R32HB.2.1m	6'10 11/16"	2.1	Slide bolt	5/16 HH	8 HH	562/3158	1849
R32HB.2.5m	8'2 7/16"	2.5	Slide bolt	5/16 HH	8 HH	562/3158	1849
R32HB.3.6m	11'9 3/4"	3.6	Slide bolt	5/16 HH	8 HH	562/3158	1849

\*Sold in pairs

### 3159 Retrofit CB-Style 4" Hole Spacing Track/Low-Beam—Fasteners 5/16" (8 mm) FH

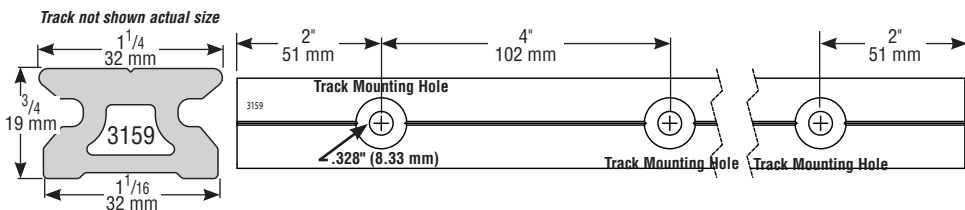

Part No.	Length		Mounting hole spacing		Fasteners		Endstop*/trim cap*	Splice link
	ft/in	m	in	mm	in	mm		
3159.6	6	1.83	4	102**	5/16 FH	8 FH	E3200/3157	3153
3159.8	8	2.44	4	102**	5/16 FH	8 FH	E3200/3157	3153
3159.12	12	3.66	4	102**	5/16 FH	8 FH	E3200/3157	3153

Not for spanning, see mounting instructions \*Sold in pairs

## CB CARS ONLY ROLL ON CB TRACK

**Note: 32 mm cars are CB style and only roll on CB track.** Older tracks do not have the grooves at the waist for the keeper wires. If cars do not fit you must replace track. Contact Harken.

### Cutting Track to Length Using Fastener Hole for Securing End Control

R32 tracks have holes drilled for E32 series stop and end controls if entire length is used. If you shorten one end, make cut so end control screw passes through a track fastening hole. It is best to have track cut with an electric cross cut saw at a machine shop. Low beam track may be cut using a hacksaw but it is difficult to get a straight, even cut. Measure from center of hole to end of track so center is  $\frac{9}{16}$ " (14 mm) from track end. If this does not work, make sure that end control screw hole does not interfere with mounting or pinstop hole. **Note: Since trim caps are not used with E32 or E27 end controls, do not leave room for them.**

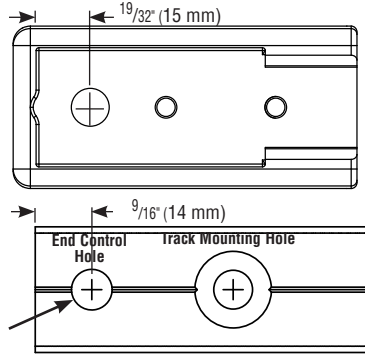

Drill Size  $\frac{13}{32}$ " (10.5 mm)

### Loader Track for Cockpit Installations

Track mounted in cockpit can make it impossible to remove car without removing the entire track. Plan ahead to avoid this problem. Cut a "loader track" section under one end control. Loader track length must be long enough to slide car off end. Measure track from finished end so that the 2nd or 3rd track fastener hole becomes the end control mounting hole depending on whether short or long cars are used. Butt anodized track ends against each other so that main and loader track align properly. Note: Loader track is required at only one end.

R32 Low-Beam Loader Track Length			
Car Length		Loader Track Length	
in	mm	in	mm
$5\frac{3}{16}$	132	$6\frac{7}{16}$	164
$7\frac{7}{16}$ / $9\frac{1}{8}$	188/232	$10\frac{3}{8}$	264

To slide the end control and car off the track, remove this section.

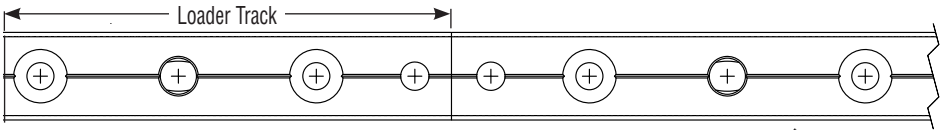

### Curved Track Limitations

Cars will not roll on curved track if the radius is under the minimum listed below. A shorter car can roll on a smaller radius. Refer to the chart below and make sure the radius is equal to or greater than the radius listed for the car. To find the radius go to [www.harken.com](http://www.harken.com).

Car	Car Length		Minimum Radius	
	in	mm	ft	m
<b>3160/3163/3164/3176/3177</b>				
T3201B, T3202B, T3203B, T3205B, T3221B, T3222B, T3231B, T3232B, T3241B, T3242B	$5\frac{3}{8}$	136	8	2.44
<b>3161/3165/3166</b>				
3172/3178/3179	$7\frac{7}{16}$	188	18	5.49
T3201B.HL, T3202B.HL, T3203B.HL, T3205B.HL, T3221B.HL, T3222B.HL, T3231B.HL, T3232B.HL, T3241B.HL, T3242B.HL				
<b>2 x 3163</b>				
T3204B.HL, T3224B.HL, T3234B.HL, T3244B.HL	15	381	8	2.44
<b>3167</b>				
T3204B, T3224B, T3234B, T3244B	$9\frac{1}{8}$	231	24	7.32

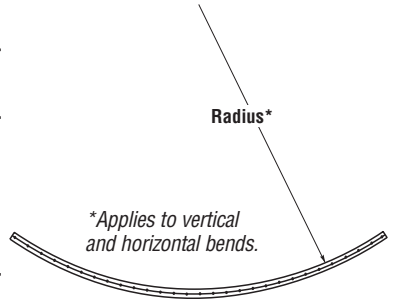

### Track for Unsupported Spans

#### 32 mm High-Beam Track Spanning Chart

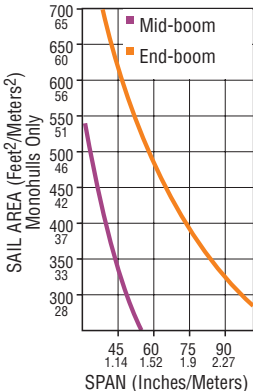

Harken high beam track is designed for unsupported spans in cockpits and companionways with additional bridge structures.

The length of span depends on the load on the car. The higher the car load the less span the track can handle. If the car is sized correctly, car length determines the spanning capability. Longer, high-load (HL) cars require shorter spans because the loads are so much greater. See track spanning chart.

Track is shipped with 8 bolt slides and Mylar washers or 10 when track is longer than 7' (2 m). Contact Harken if more slides or washers are required. Part numbers: Slides HCP164. Washers HCP131.

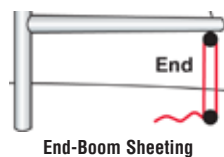
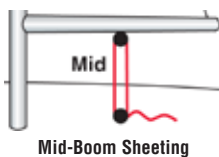

## Fasteners

Carefully choose fasteners that are made from A4 (316) or A2 (18-8) stainless steel. Make sure to use large washers or backing plates and lock washers or locknuts. It is installer's responsibility to choose correct screws, nuts, washers, and threaded plates, taking account materials and loads they will have to bear. Harken® assumes no responsibility for incorrect installation of track or for an incorrect choice of mounting fasteners.



**WARNING! Use correct number and type of fasteners in A4 (316) or A2 (18-8) stainless steel. Fasteners made of other materials may not have sufficient strength or may corrode which can result in track pulling off deck suddenly and unexpectedly during high loads, possibly causing severe injury or death.**

## Deck Strength

Traveler track must be installed on a flat area of deck, reinforced if necessary to bear a load equal to at least twice maximum working load of traveler car to be used. It is installer's responsibility to carry out all structural tests needed to ensure that deck can bear load. Consult the yard that built the boat in case of doubt over the correct track position and deck strength. Harken® assumes no responsibility for incorrect installation of track or for an incorrect choice of mounting screws



**WARNING! Failure to ensure the correct deck strength can result in the track pulling off the deck suddenly and unexpectedly during high loads, possibly causing severe injury or death.**

## Mounting Low-Beam Track

Carefully choose mounting screws by consulting charts and warnings above. R32 track requires  $\frac{3}{8}$ " or 10 mm flathead stainless steel screws (see "Fasteners" above). Retrofit 3159 track requires  $\frac{5}{16}$ " (8 mm) flathead screws. Be sure which track you have.

Carefully drill holes and apply high quality sealant. Through-bolt track using all fastener holes. Secure under the deck using large washers or backing plate and washers and locknuts.

**Low-beam track must not be used for spanning.**

## Mounting High-Beam Track on Unsupported Spans

Place at least three (3) bolts at each end of the track, with two (2) bolts placed immediately next to each inboard end of the span. For the remainder of the supported beam, place bolts on 4" (102 mm) centers.

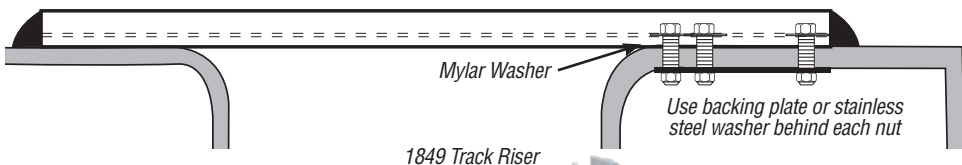

To mount track, calculate hole spacing and drill desired holes in deck, seats or other mounting surface. Place appropriate number of  $\frac{9}{16}$ " (8 mm) hexhead bolts on bolt slides and slip into groove in bottom of track.

Place one Mylar washer (included) on each bolt under track.

These washers force sealant into mounting holes to insure a good seal.

Apply high quality sealant to mounting surface around each hole. Place

bolts into holes and lower track. Bolt securely using lock washers or lock nuts. Most mounting surfaces will require a backing plate for proper strength.

**Low-beam track must not be used for spanning.**



**WARNING! Using track not intended for spanning or failure to follow spanning recommendations may result in track pulling off deck suddenly and unexpectedly during high loads, possibly resulting in severe injury or death.**

## Inspect

Carefully inspect track and mounting hardware for any signs of loosening, cracks or damage. Inspect end stops to make sure they are secure and that there are no cracks or damage. Arrange control tackle so cars do not hit end stops under load.



**WARNING! Failure to inspect tracks and stops can result in track pulling off deck suddenly and unexpectedly during high load, possibly causing severe injury or death.**

## Maintenance

**Traveler Cars:** Clean by frequently flushing with fresh water. Periodically clean car by squirting a detergent/water solution into center openings. Roll car back and forth to distribute evenly then flush bearings with fresh water.

Do not use spray lubricants because ball bearings may skid not roll. Apply a few drops of McLube® OneDrop™ to ball contact surfaces of track. Roll car back and forth through OneDrop™ several times to distribute onto bearings. Wipe remaining OneDrop™ off track. OneDrop™ is preferred but you can also use one to two drops of a light machine oil, such as 3-in-1. Too much oil attracts dirt.

**Track:** Clean with detergent and water.

**Important:** Exposure to some teak cleaners and other caustic solutions can result in discoloration of part and is not covered under the Harken warranty.



## Warranty

For additional safety, maintenance and warranty information see [www.harken.com](http://www.harken.com) or the Harken® catalog.