

HARKEN®

USA – Tel: (+01) 262-691-3320 • Web: www.harken.com • Email: harken@harken.com
 Italy – Tel: (+39) 031.3523511 • Web: www.harken.it • Email: techservice@harken.it

ONLINE INSTRUCTIONS

27 mm Midrange Endstops and End Controls (Sold as a Pair)

E2700, E2720, E2730, E2740, E2746, E2750
 Fits R27 and Midrange CB Track



Strictly follow all instructions to avoid an accident, damage to your vessel, personal injury or death. See www.harken.com for additional safety information.

IMPORTANT: See Inspection and Maintenance at end of manual.

Features

- Modular design:** easy to change configuration
- Removable dead-end bail:** easy to load splice
- Ball Bearing sheaves:** low friction traveler control

Fasteners — Not Included

Fasteners (One Set for Each Control):

1 (one) 5/16" (8 mm) flathead A4 (316) or A2 (18-8) stainless steel mounting screw.

End control and track thickness is shown at right.

When purchasing fasteners, add deck thickness and enough threads to extend below washer and nut.

1 (one) washer

1 (one) locknut for each end control.

Drill Bit: 11/32" (8.5 mm)

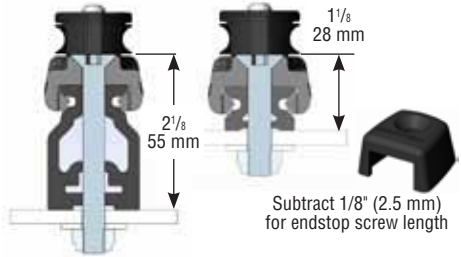

Dimensions

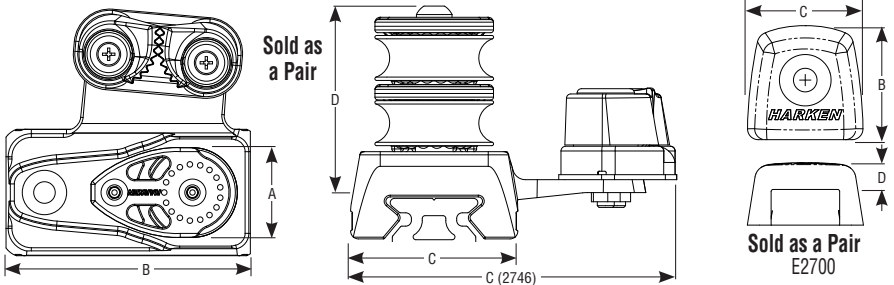

Part No.	Sheave Ø		A		B		C		D Height above track		Max line Ø		Maximum working load		Breaking load		Purchase
	in	mm	in	mm	in	mm	in	mm	in	mm	in	mm	lb	kg	lb	kg	
E2700	—	—	2	51	1 ¹³ / ₁₆	47	3/8	10	—	—	—	—	—	—	—	—	—
E2720	1 ³ / ₈	35	3 ³ / ₄	95	1 ¹³ / ₁₆	45	1 ⁷ / ₁₆	36	3/8	10	1800	816	3600	1633	1:1		
E2730	1 ³ / ₈	35	3 ³ / ₄	95	1 ¹³ / ₁₆	45	1 ⁷ / ₁₆	47	3/8	10	1800	816	3600	1633	2:1		
E2740	1 ³ / ₈	35	3 ³ / ₄	95	1 ¹³ / ₁₆	45	2 ¹ / ₃₂	56	3/8	10	1800	816	3600	1633	3:1		
E2746	1 ³ / ₈	35	3 ³ / ₄	95	3 ¹³ / ₁₆	96	2 ¹ / ₃₂	56	3/8	10	600	272	1500	680	3:1		
E2750	1 ³ / ₈	35	3 ³ / ₄	95	1 ¹³ / ₁₆	45	2 ⁵ / ₈	67	3/8	10	1800	816	3600	1633	4:1		

Mounting to Track

Note: E27 end controls do not fit older non-CB track. The E27 end controls' interior ridges that extend into the waist of the track are too deep to fit non-CB track. E27 end controls require deep grooves for wire keepers on CB cars.

E27 end controls require deep grooves for wire keepers on CB cars



R27 low-beam track has holes drilled for end controls and endstops if entire length is used. If you shorten one end, make cut so end control screw passes through a track fastening hole. It is best to have track cut with an electric cross cut saw at a machine shop. Low beam track may be cut using a hacksaw but it is difficult to get a straight, even cut. Measure from center of hole to end of track so center is 9/16" (14 mm) from track end. If this does not work, make sure that end control screw hole does not interfere with mounting or pinpoint hole.

Note: Since trim caps are not used with E27 or E32 end controls, do not leave room for them.

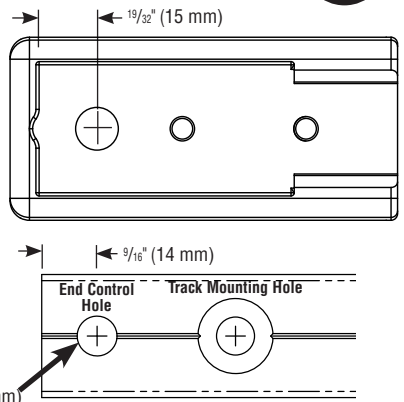

Drill Size 11/32" (8.5 mm)

Mounting End Controls and End Stops

Use a $\frac{5}{16}$ " (8 mm) flathead screw. Carefully choose fasteners that are made from A4 (316) or A2 (18-8) stainless steel.

Run screw through end control and track then secure under the deck using a large washer or backing plate and washer and locknut. Make sure deck is reinforced to handle traveler loads.

Use large washers or backing plates and lock washers or locknuts. It is installer's responsibility to choose correct screws, nuts, washers, and threaded plates, taking account materials and loads they will have to bear. Harken® assumes no responsibility for incorrect installation of end controls or for an incorrect choice of mounting fasteners.



WARNING! Use correct number and type of fasteners in A4 (316) or A2 (18-8) stainless steel. Fasteners made of other materials may not have sufficient strength or may corrode which can result in end controls pulling off track suddenly and unexpectedly during high loads, possibly causing severe injury or death.

Attaching Splice to Deadend on Car or Controls

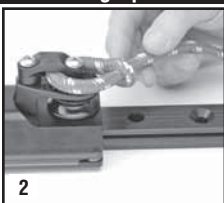

- 1) Loosen one bail screw on car or end control. Remove other screw and rotate bail to capture splice loop. Install screws using a threadlocker such as blue Loctite® on screws.
- 2) When using smaller control line pass eye through bail and run tail through to make a hitch without undoing bail.

Reeving Cars and End Control Blocks

2:1 Purchase

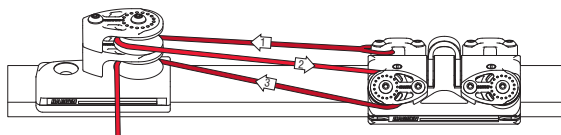
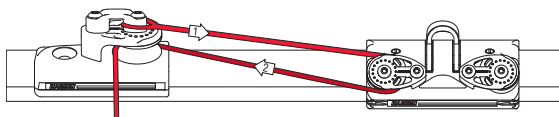

3:1 Purchase

4:1 Purchase

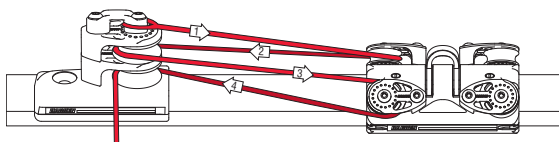

Inspect

Carefully inspect track and mounting hardware for any signs of loosening, cracks or damage. Inspect end stops to make sure they are secure and that there are no cracks or damage. Arrange control tackle so cars do not hit end stops under load.



WARNING! Failure to inspect tracks and stops can result in track pulling off deck suddenly and unexpectedly during high load, possibly causing severe injury or death.

Maintenance

Traveler Cars: Clean by frequently flushing with fresh water. Periodically clean car by squirting a detergent/water solution into center openings. Roll car back and forth to distribute evenly then flush bearings with fresh water.

Do not use spray lubricants because ball bearings may skid not roll. Apply a few drops of McLube® OneDrop™ to ball contact surfaces of track. Roll car back and forth through OneDrop™ several times to distribute onto bearings. Wipe remaining OneDrop™ off track. OneDrop™ is preferred but you can also use one to two drops of a light machine oil, such as 3-in-1. Too much oil attracts dirt.

Track: Clean with detergent and water.

Important: Exposure to some teak cleaners and other caustic solutions can result in discoloration of part and is not covered under the Harken warranty.



Warranty

For additional safety, maintenance and warranty information see www.harken.com or the Harken® catalog.