

40STQ

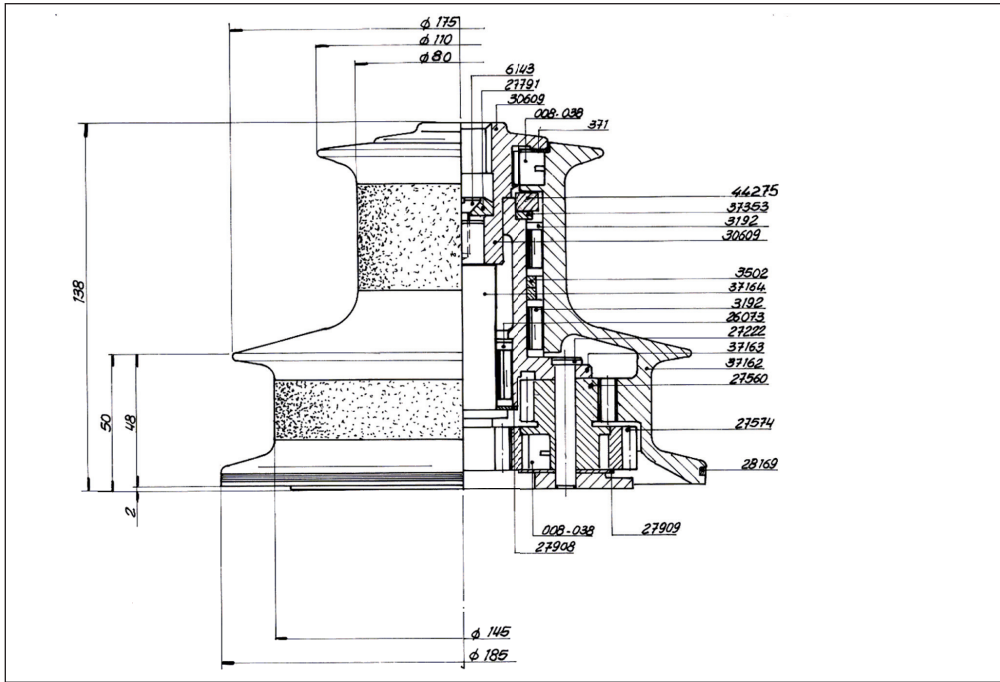

40Q

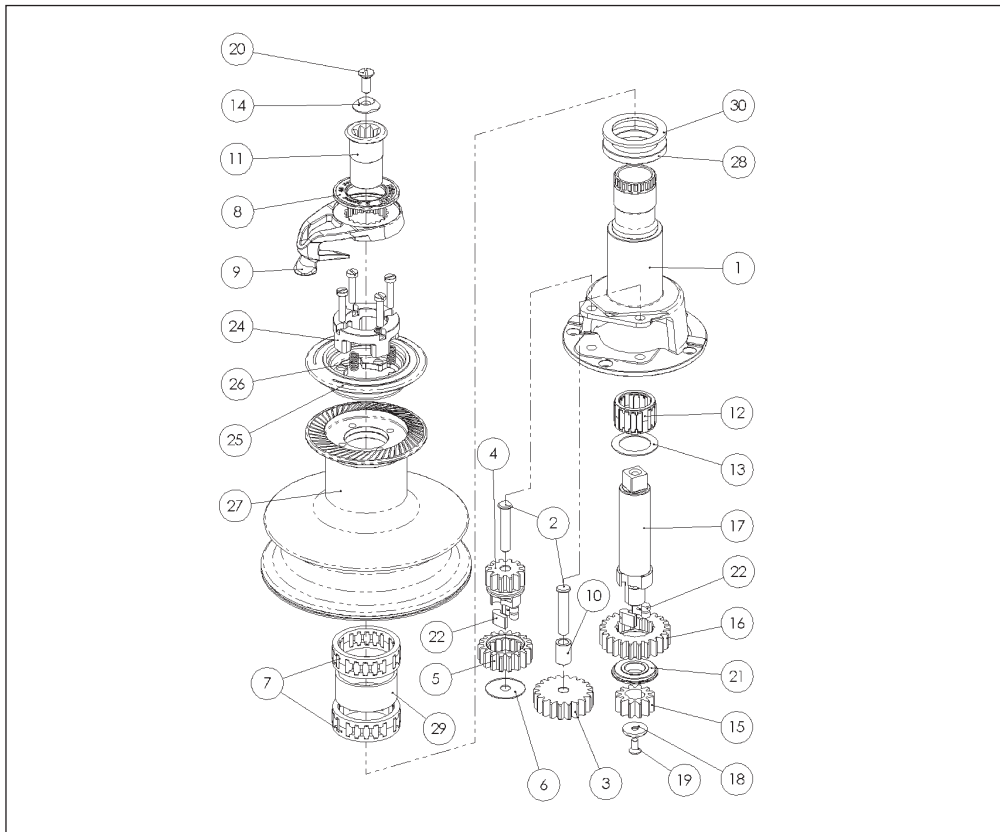

Required Tools

- Screwdriver
- Allen Wrench (6 mm)
- Allen Wrench (5 mm for Self Tailing)
- Plastic Head Hammer or Mallet
- Small Knife
- Brush
- Rags
- Solvent
- Oil
- Grease

Suggested Service Kits

BK4512	10	008 Pawls
	10	038 Springs
BK4513	100 ml Grease	

When ordering parts, please include a "B" before each number (i.e. B008).

Service winch before the sailing season begins and once during.

■ Installing Winch

- Make sure mounting surface is flat.
- Check sheet entry angle. Should be at least 8° (see drawing).
- Open winch.
- Position winch on deck with drive gear where sheet enters winch drum. Mark holes.
- Remove winch and drill holes.
- Mount using five (5) ¼" (6 mm) flathead machine screws.
- Apply bedding compound. Bolt winch to boat.
- Clean excess bedding compound from base drain holes.
- Lubricate and close winch.

■ Minimum/Maximum Line Diameter

- Harken winches feature spring-loaded self-tailing jaws which adjust automatically to the following line sizes:
- Minimum 5/16" (8 mm)
- Maximum 1/2" (12 mm)

■ Positioning Stripper Arm

- Loosen top screw.
- Remove handle socket.
- Lift stripper arm and position as desired.

■ Opening Winch

- Remove top screw.
- Lift off drum and stripper arm.

■ Servicing Winch

- Remove pawls and springs - service as below.
- Remove bearing, gear shaft and gears.
- To reach interior shaft bearing, winch must be removed from deck.
- Clean all parts except 37335, 37336 and 37337 with rag and solvent.
- Important: Use freshwater only on parts 37335, 37336 and 37337.
- Use brush to lubricate all moving parts lightly with grease.
- Replace pawls and springs and lubricate lightly with oil.
- Assemble and close winch.

■ Servicing Pawls

- Catch spring with knife and hold against pawl.
- Lift out pawl.
- Clean and check for wear.
- Place spring against pawl with straight leg against pawl.
- Hold spring closed and slip pawl into pawl socket.
- Lubricate pawls using oil.

WARNING

EN: Do not allow teak cleaning products or other cleaners containing caustic solutions to come into contact with winches and especially anodized, chrome plated or plastic parts.

F: Évitez soigneusement tout contact de nettoyant pour teck ou autres produits de nettoyage avec les winchs et plus particulièrement avec les pièces en aluminium anodisé, en métal chromé ou en plastique.

D: Keine Teak - Reiniger oder andere Reiniger die ätzende Stoffe enthalten, mit Winschen, eloxierten, verchromten oder Kunststoffteilen in Berührung bringen.

I: Evitare il contatto dei prodotti per la pulizia del teak e di altre sostanze pulenti contenenti soluzioni caustiche con i winch e in particolare con i componenti anodizzati, cromati e plastici dei winch.

E: Evitar que los productos especiales para la limpieza de la Teca o cualquier otro limpiador que contengan soluciones cáusticas, entren en contacto con los Winches y en particular con componentes cromados, plateados o anodizados así como con las piezas de plástico.

HARKEN®

USA: 1251 E. Wisconsin Ave., Pewaukee, WI 53072 USA • Tel: (262) 691-3320 • Fax: (262) 691-3008 • Web: harken.com • E-mail: harken@harken.com
ITALY: Via Della Cerca, 12/14, 22070 Lurago Marinone, Como, Italy • Fax: (39) 031.3520031 • Tel: (39) 031.3523511 • Web: harken.it • E-mail: info@harken.it

Mounting

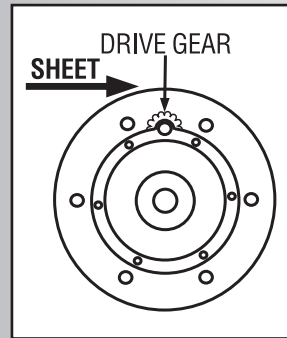

Position drive gear where sheet enters winch drum.

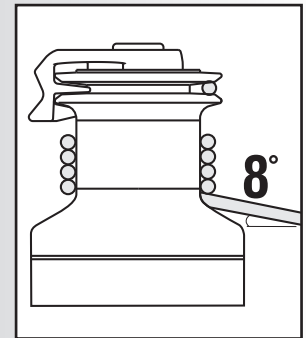

Sheet entry angle must be at least 8°.

Servicing Winch

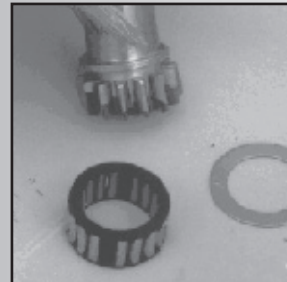

Clean all parts, except 37335, 37336, and 37337, with solvent.

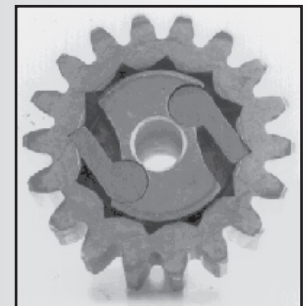

Use a brush to spread a light, even coat of grease.

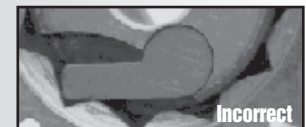
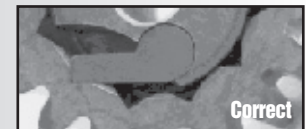

If ratchet gear is mounted backwards, winch will slip.

Servicing Pawls

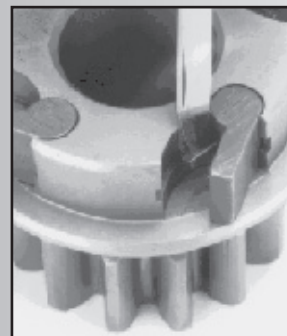

Use knife to free captive spring.

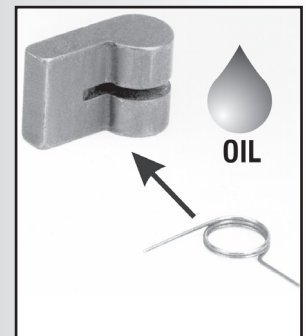

Insert spring with straight leg against pawl. Use oil for lubrication.