

## #254 Lazy Jack Kit

Boats 35 – 42 ft.

(10.7 – 12.8 m)

Booms

12 – 16 ft. (3.7 – 4.9 m)

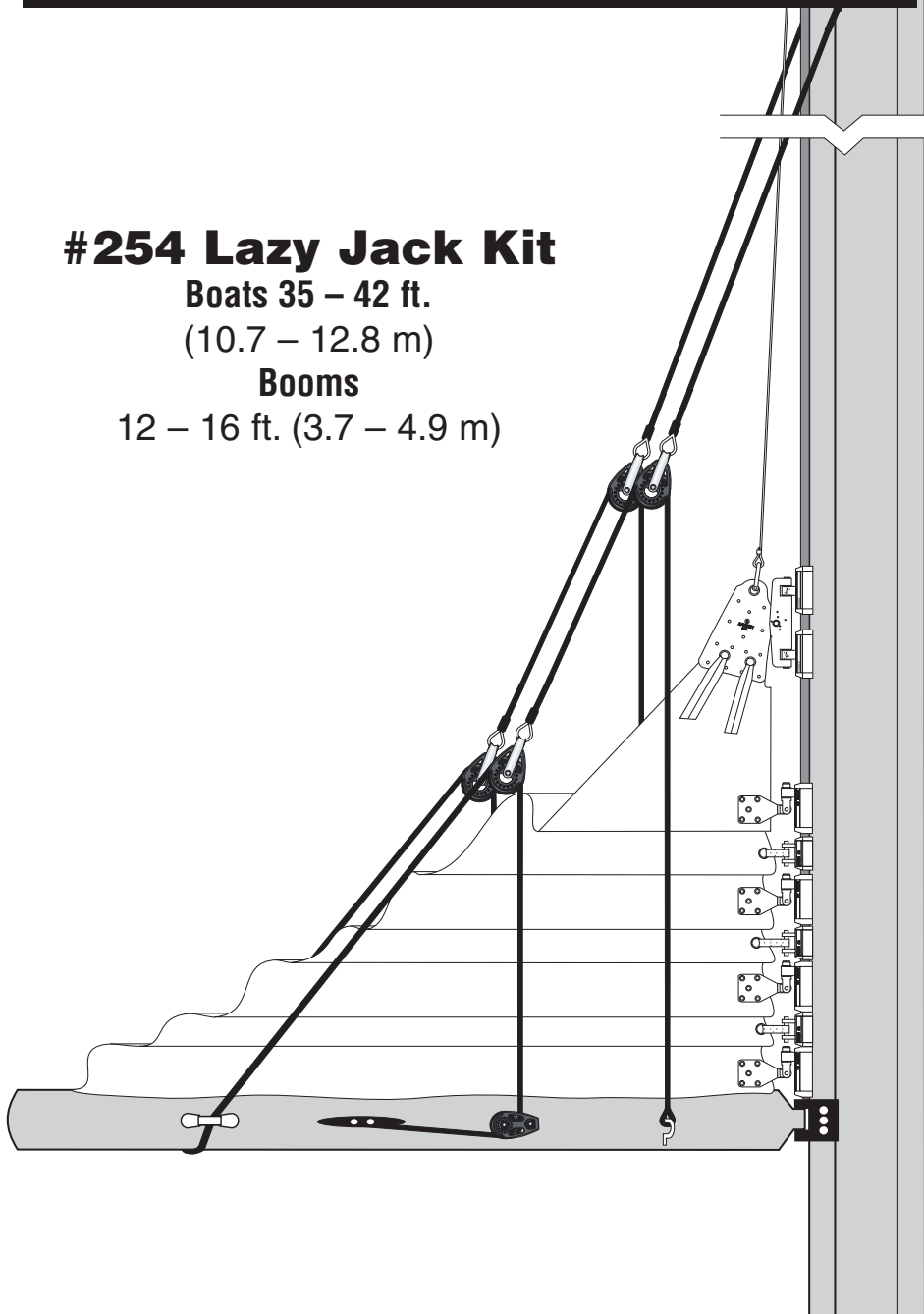

## Parts List

- 2 6' (1.82 m) wire assemblies including blocks and mast tangs
- 2 30'6" (9.29 m) upper line assemblies with blocks
- 1 104' (31.69 m) adjusting line
- 5 H073 Stainless steel eyestraps
- 1 H132 Big Bullet cheek block
- 1 4" (101 mm) aluminum cleat
- 21  $\frac{3}{16}$ " (4.76 mm) stainless steel rivets (includes 3 extra)
- 21 10-32 x .375 slotted trusshead machine screws
- 3 #10 x  $1\frac{1}{4}$ " (32 mm) flathead self-tapping screws (includes 1 extra)
- 3 10-32 x  $\frac{3}{4}$ " (19 mm) trusshead machine screws (includes 1 extra)
- 3 #10 x  $\frac{3}{4}$ " (19 mm) trusshead self-tapping screws (includes 1 extra)

## Tools Required

Marker or pencil

Center punch

Hammer

**Drill, Tap & Screw Method:**

1 – 1 slotted screwdriver

1 –  $\frac{5}{32}$ " (4 mm) drill bit

1 – 10-32 tap set

**Rivet Gun Method**

Stainless steel rivets require a heavy-duty rivet gun. It may be necessary to rent a rivet gun if you do not have a heavy-duty model.

Drill Bit –  $\frac{13}{64}$ " (5 mm)

$\frac{5}{32}$ " (4 mm) drill bit

Tape measure (long enough to measure luff length)

Electric drill

## Topping Lift

To avoid snagging the mainsail on the Lazy Jacks when raising sail, the boat must be equipped with a topping lift or vang that holds boom lifted.

## Altering Sail Cover

Take your sail cover to a sailmaker to have slits cut in the cover for the Lazy Jacks.

Slits should have Velcro or snap closures to make it easy to cover the mainsail.

Mark your cover after installation so the slits can be positioned correctly.

## Determining the Location of Mast Tang

Measure the mainsail luff length or find the "P" dimension of the mast. Find this measurement in the left column below and circle the number in the right column.

See drawing, page 3.

| Chart A<br>If the mainsail luff length or<br>P dimension measures: |                 | The tang location<br>measured from the<br>top of the boom is: |        | If the mainsail luff length or<br>P dimension measures: |                 | The tang location<br>measured from the<br>top of the boom is: |        |
|--|-----------------|---|--------|---|-----------------|---|--------|
| 35'7" to 36'   | 10.85 - 10.97 m | 23'5"   | 7.14 m | 42'1" to 42'6"  | 12.83 - 12.95 m | 27' 7"  | 8.41 m |
| 36'1" to 36'6"   | 11.00 - 11.13 m | 23'9"   | 7.24 m | 42'7" to 43'  | 12.98 - 13.11 m | 27'11"  | 8.51 m |
| 36'7" to 37'   | 11.15 - 11.28 m | 24'1"   | 7.34 m | 43'1" to 43'6"  | 13.13 - 13.26 m | 28' 3"  | 8.61 m |
| 37'1" to 37'6"   | 11.30 - 11.43 m | 24'4"   | 7.42 m | 43'7" to 44'  | 13.28 - 13.41 m | 28' 7"  | 8.71 m |
| 37'7" to 38'   | 11.46 - 11.58 m | 24'8"   | 7.52 m | 44'1" to 44'6"  | 13.44 - 13.56 m | 28'11"  | 8.81 m |
| 38'1" to 38'6"   | 11.61 - 11.73 m | 25'   | 7.62 m | 44'7" to 45'  | 13.59 - 13.72 m | 29' 3"  | 8.92 m |
| 38'7" to 39'   | 11.76 - 11.89 m | 25'4"   | 7.72 m | 45'1" to 45'6"  | 13.74 - 13.87 m | 29' 7"  | 9.02 m |
| 39'1" to 39'6"   | 11.91 - 12.04 m | 25'8"   | 7.82 m | 45'7" to 46'  | 13.89 - 14.02 m | 29'11"  | 9.12 m |
| 39'7" to 40'   | 12.07 - 12.19 m | 26'   | 7.92 m | 46'1" to 46'6"  | 14.05 - 14.17 m | 30' 3"  | 9.22 m |
| 40'1" to 40'6"   | 12.22 - 12.34 m | 26'4"   | 8.03 m | 46'7" to 47'  | 14.20 - 14.33 m | 30' 7"  | 9.32 m |
| 40'7" to 41'   | 12.37 - 12.50 m | 26'8"   | 8.13 m | 47'1" to 47'6"  | 14.35 - 14.48 m | 30'10"  | 9.40 m |
| 41'1" to 41'6"   | 12.52 - 12.65 m | 27'   | 8.23 m | 47'7" to 48'  | 14.50 - 14.63 m | 31' 2"  | 9.50 m |
| 41'7" to 42'   | 12.67 - 12.80 m | 27'4"   | 8.33 m | —   | —               | —   | —      |

## Installing Mast Tang and Wire Assembly

If you are installing system with the mast up, take the following parts up in the bosun's chair or send them up with a messenger line. (Follow all precautions to insure the safety of the person aloft. Use a safety halyard and make sure halyards are in good condition. Make sure no one is standing where they could be hit with dropped tools.)

**WARNING! When drilling through mast, do not let drill bit contact the halyard that is holding you aloft! This may cause the halyard to fail. Limit depth.**

Tape measure

Port and starboard templates (attached to pg. 3)

Tape for template

Tang assembly including wires and blocks

Hammer

Center punch

**Screw Method**

Drill with  $\frac{5}{32}$ " (4 mm) drill bit

#10-32 Tap & Handle

Slotted Screw Driver

**Rivet Method**

Drill with  $\frac{13}{64}$ " (5 mm) drill bit

Rivet Gun

**Note: before going up the mast, insert the middle screw or rivet into the tang.**

Squeeze the top and bottom of the tang together to insert the screw or rivet. It may be necessary to use a pliers or vice grips.

Measure up from the top of the boom to the height from chart A (page 2).

Moveable Gooseneck - If the gooseneck is capable of moving up and down, measure from the top of the boom when the boom is positioned in its normal sailing position.

Mark the mast at this point.

Tape the template to the side of the mast so the middle hole is even with your mark.

Line the template up so the vertical line is parallel to the side of the mast. See drawing below.

Use center punch to mark (4) four tang holes. Remove template and drill (4) four holes.

**DRILL HOLES: Screws  $\frac{5}{32}$ " (4 mm) & Tap #10-32      Rivets  $\frac{13}{64}$ " (5 mm)**

Attach tang beginning with center holes.

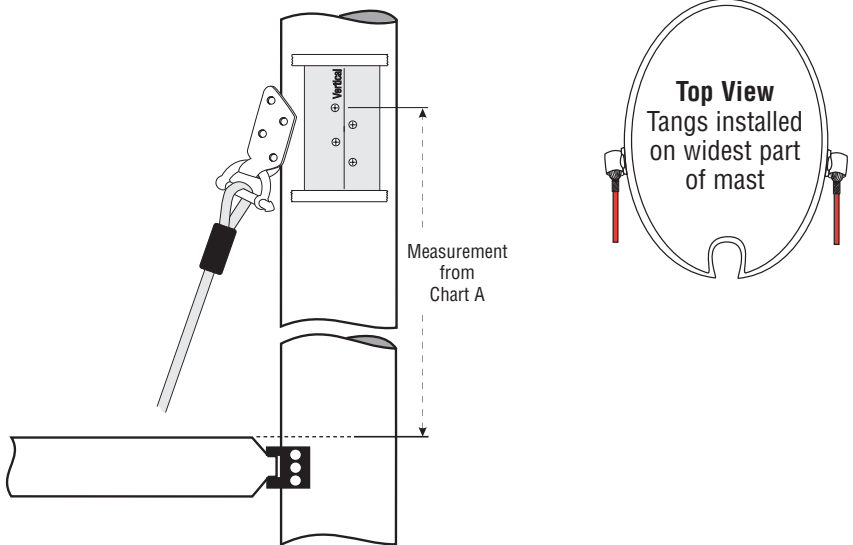

## Stringing Upper Line Assemblies

String upper line assemblies through blocks so line splice is forward and blocks aft.

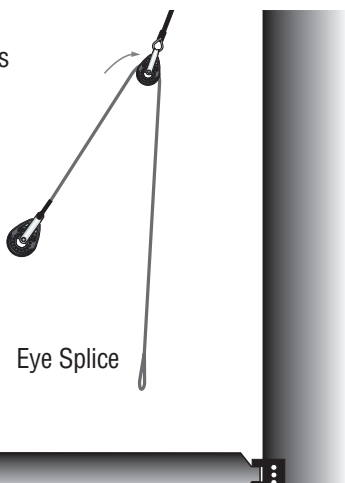

## Determining the Location of Boom Hardware\*

Measure mainsail foot length or find E dimension of mast. Find this measurement in left column below and circle the corresponding numbers in right column. Put a mark on each side of boom at each measurement. See drawing, page 5.

| "E" Dimension or Sail Foot Length |               | Forward Eystrops | Cheek Block and Middle Eystrops | Aft Eystrops     |
|-----------------------------------|---------------|------------------|---------------------------------|------------------|
| 11'7" to 12'                      | 3.53 - 3.66 m | 2' 4" (.70 m)    | 5' 6" (1.676 m)                 | 8'10" (2.692 m)  |
| 12'1" to 12'6"                    | 3.68 - 3.81 m | 2' 6" (.76 m)    | 5' 9" (1.753 m)                 | 9' 3" (2.819 m)  |
| 12'7" to 13'                      | 3.84 - 3.96 m | 2' 7" (.79 m)    | 6' - (1.829 m)                  | 9' 7" (2.921 m)  |
| 13'1" to 13'6"                    | 3.99 - 4.11 m | 2' 8" (.82 m)    | 6' 3" (1.905 m)                 | 10' - (3.048 m)  |
| 13'7" to 14'                      | 4.14 - 4.27 m | 2'10" (.85 m)    | 6' 6" (1.981 m)                 | 10' 4" (3.150 m) |
| 14'1" to 14'6"                    | 4.29 - 4.42 m | 2'11" (.88 m)    | 6' 9" (2.057 m)                 | 10' 9" (3.277 m) |
| 14'7" to 15'                      | 4.45 - 4.57 m | 3' - (.91 m)     | 6'11" (2.108 m)                 | 11' 1" (3.378 m) |
| 15'1" to 15'6"                    | 4.60 - 4.72 m | 3' 1" (.94 m)    | 7' 2" (2.184 m)                 | 11' 6" (3.505 m) |
| 15'7" to 16'                      | 4.75 - 4.88 m | 3' 2" (.97 m)    | 7' 5" (2.261 m)                 | 11'10" (3.607 m) |

\*Note - You may want to check sail containment before drilling holes in boom. To do this, put sail on, tape boom hardware in place, reeve lines through system and lower sail. Move if necessary.

## Installing Forward Eyestrap

Hold eyestrap on side of boom even with forward marks. Align feet of eyestrap vertically as pictured. Mark holes. Attach eyespllices of upper line assembly to eyestraps and screw or rivet one to each side of the boom.

**DRILL HOLES: Screws**  $\frac{5}{32}$ " (4 mm)  
**Rivets**  $\frac{13}{64}$ " (5 mm)

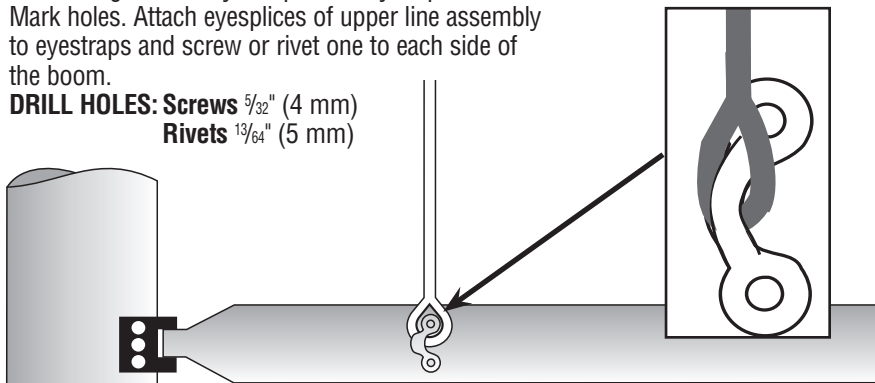

## Installing Cheek Block

Decide which side of mast you wish to install adjusting cheek block and if cleat will be fore/aft of cleat. Screw or rivet cheek block even with middle mark on boom, so sheave side of block is towards cleat. Use  $\frac{3}{4}$ " (19 mm) long trusshead machine or self-tapping screws.

**DRILL HOLES: Machine Screws  $\frac{5}{32}$ " (4 mm) and Tap 10-32**

**Self-Tapping Screws:  $\frac{5}{32}$ " (4 mm)**

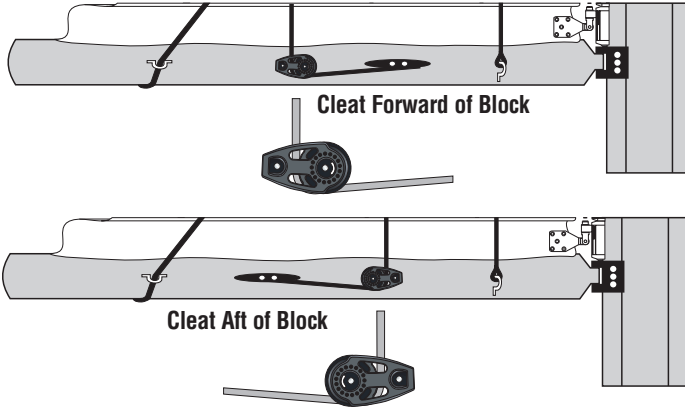

## Installing Adjusting Line

Separate the 104' (31.69 m) length of line into 2 coils.

**Do not cut!** Lay a coil on each side of the aft half of the boom so the side without the splice is below the cheek block. String each coil of adjusting line through lower blocks so line is cradled under the boom.

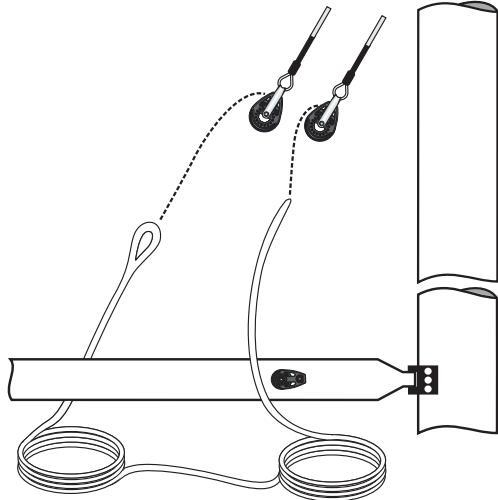

## Installing Middle Eyestrapp

Attach eyesplice of adjusting line to the midboom eyestrapp and screw or rivet to mast opposite the cheek block.

**DRILL HOLES:**

**Screws  $\frac{5}{32}$ " (4 mm)**

**Rivets  $\frac{1}{64}$ " (5 mm)**

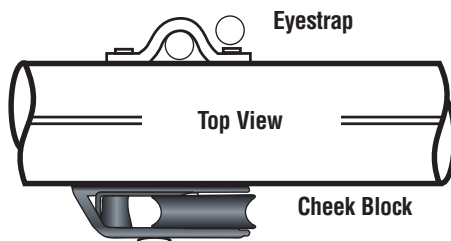

## Installing Aft Eyestraps

String end of adjusting line through cheek block. Captivate line in eyestraps on each side of boom so line is even with your aft marks. Screw or rivet eyestraps to each side of boom.

**DRILL HOLES: Machine Screws  $\frac{5}{32}$ " (4 mm) Rivets  $\frac{13}{64}$ " (5 mm)**

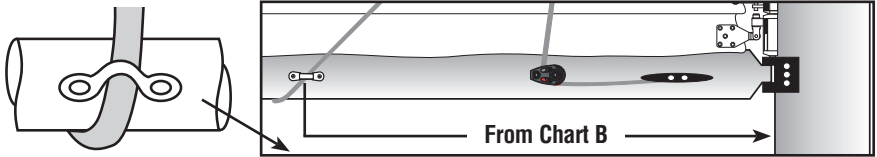

## Installing Adjuster Cleat

Choose a place for adjuster cleat. Drill holes using  $\frac{5}{32}$ " (4 mm) drill bit and mount cleat using #10 x  $1\frac{1}{4}$ " flathead sheet metal screws (included).

*Tip: Once you have threaded the screws into boom, remove them and file off ends so they do not interfere with internal boom lines.*

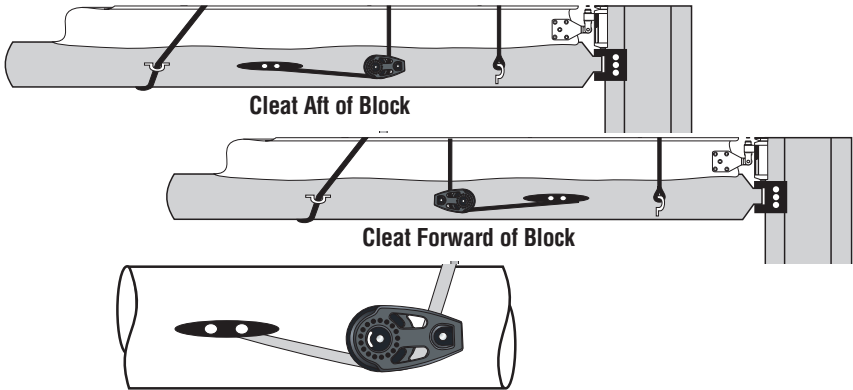

## Using Shock Cord to Pull Lazy Jacks Outward

We recommend shock cord to hold Lazy Jacks open to make it easier to raise sail.

1. Attach shock cord to end of lower spreaders. Hog rings work well for this purpose. Use rigging tape over hog rings.
2. Temporarily tie other end of shock cord to Lazy Jacks at a length that holds Lazy Jacks out, but not so short that spreaders will be damaged when boom is swung out.
3. Test length by swinging boom all the way out. If necessary, lengthen shock cord before permanently attaching to Lazy Jacks.

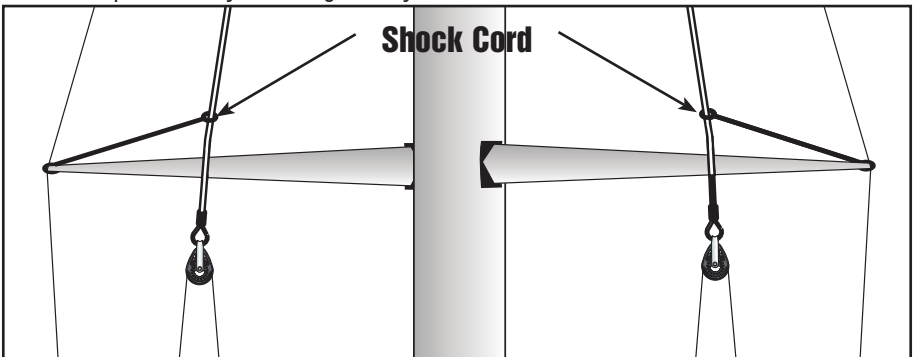

## **Conventional Sail Slugs**

If using conventional sail slugs, make sure slugs are free to move below the gate. Use mast gate plates so sail slugs stay in the mast groove. Contact your rigger.

## **Adjusting Lazy Jacks**

Raise the mainsail and make sure adjusting line is uncleated at boom. Tighten the mainsheet as tight as it will go to find maximum distance the boom would be lowered while under sail. Next, tighten adjusting line and slack it off about 3" so it will not interfere with sail shape. A little fine tuning may be necessary.

## **Using Your Lazy Jacks - Precautions**

Before sailing, make sure Lazy Jacks will not catch on spreaders. While at dock, swing boom out so sail is against spreader tips. Try lifting boom and shaking to see if Lazy Jack lines are apt to swing behind spreaders. When first sailing with Lazy Jacks, look aloft while sailing downwind to see if Lazy Jacks catch behind spreaders. If they get snagged while sailing, release snagged Lazy Jacks from behind spreader before bringing mainsail in towards center. If this is not done, you risk breaking spreaders as mainsheet is tensioned and mainsail moves toward the centerline.

If Lazy jacks are prone to snagging spreader tips, there are 2 solutions. The easiest is to rig shock cords to pull Lazy Jacks forward out of way of spreader tips. Rig a length of shock cord on each side of sail. Dead end shock cord at or near gooseneck and run it up to blocks which are suspended from wires.

If this does not help, you will need to reposition Mast Tangs so they are lower on mast and do not interfere with spreader tips.

Lazy Jacks are designed to neatly contain mainsail on boom when you lower or reef sails. Please contact us if you have any questions or comments.

## **Raising Sail**

When hoisting sail, check to make sure the sail does not get caught in the Lazy Jacks. The headboard or battens may catch between the mast and the Lazy Jacks or jam in the angle between the lines. If the halyard is forced, this could result in a broken batten, ripped sail or damaged Lazy Jack. To avoid this, look aloft as you raise the mainsail and stop if the sail gets caught. Also, make sure the boat is facing head-to-wind. The sail is less apt to catch on the Lazy Jacks if the topping lift is used and the Lazy Jacks are somewhat loose. This way they will deflect out of the way easier when the sail makes contact with them.

# **HARKEN®**

## ***Corporate Headquarters***

1251 East Wisconsin Avenue, Pewaukee, Wisconsin 53072 USA  
Telephone: (262) 691-3320 • Fax: (262) 691-3008 • Cable: Harken Pewaukee  
Web: [www.harken.com](http://www.harken.com) • Online Catalog: [www.harkenstore.com](http://www.harkenstore.com)  
Email: [harken@harken.com](mailto:harken@harken.com)

## ***Harken France***

ZA. Port des Minimes, BP 3064, 17032 - La Rochelle Cedex 1, France  
Telephone: (33) 05.46.44.51.20 • Fax: (33) 05.46.44.25.70  
Web: [www.harken.fr](http://www.harken.fr)  
Email: [harken@harken.fr](mailto:harken@harken.fr)

## ***Harken Italy S.P.A.***

Via Marco Biagi, 14, 22070 Limido Comasco, (CO), Italy  
Telephone: (39) 031.3523511 • Fax: (39) 031.3520031  
Web: [www.harken.it](http://www.harken.it)  
Email: [info@harken.it](mailto:info@harken.it)

## ***Harken UK Ltd.***

Bearing House, Ampress Lane  
Lymington, Hampshire SO41 8LW, England  
Telephone: (44) 01590-689122 • Fax: (44) 01590-610274  
Web: [www.harken.co.uk](http://www.harken.co.uk)  
Email: [enquiries@harken.co.uk](mailto:enquiries@harken.co.uk)

## ***Harken Poland***

ul. Lisa Kuli 4 Lok.1, 01-512 Warszawa, Polska  
Telephone: +48 607 979 747  
Web: [www.harken.com](http://www.harken.com)  
Email: [polska@harken.com](mailto:polska@harken.com)

## ***Harken Sweden***

Mjölkekilsgatan 8, Box 64  
S-440 30 Marstrand, Sweden  
Telephone: (46) 303-618 75 • Fax: (46) 303-618 76  
Web: [www.harken.se](http://www.harken.se)  
Email: [harken@harken.se](mailto:harken@harken.se)

## ***Harken Adriatik d. o. o.***

Obala 107  
6320 Portoroz, Slovenia  
Telephone/Fax: 5-6774122  
Web: [www.harken.si](http://www.harken.si)  
Email: [info@harken.si](mailto:info@harken.si)

## ***Harken Australia, Pty, Ltd.***

1B Green Street  
Brookvale, N.S.W. 2100, Australia  
Telephone: (61) 2-8978-8666 • Fax: (61) 2-8978-8667  
Web: [www.harken.com.au](http://www.harken.com.au)  
Email: [info.harken.com.au](mailto:info.harken.com.au)

## ***Harken New Zealand, Ltd.***

30-36 Fanshawe Street  
Auckland 1001, New Zealand  
Telephone: (64) 9-303-3744 • Fax: (64) 9-307-7987  
Web: [www.harken.co.nz](http://www.harken.co.nz)  
Email: [harken@harken.co.nz](mailto:harken@harken.co.nz)

Please visit: <http://www.harken.com/dealers/dealers.php>  
for an up-to-date list of Harken dealers and distributors